



IRD Swiss

IRD Swiss - Am Wasserwerk 7, D-08340 Schwarzenberg, Germany
Tel.: +49 (0) 3774-1807421, Fax: +49 (0) 3774-1807424
Mobil: +49 (0) 178 8082390, eMail: ird-swiss@t-online.de

We thank for your enquiry and would submit with pleasure in bank order with no binding and exemptible according the German rules VDW-502 the following items:

18 units **Wind turbine generator with active-blade control**
MITSUBISHI MWT 500
500 KW
40m rotor diameter; 40m tubular steel tower

Year of building:	1999
Usage:	used but excellent condition, permanent maintained
Location:	Portugal
Transformer:	Inclusive transformer;
Gearbox:	planetary/helical gear
Not included:	dismantling

Single-Price without tax, ex place:	129.000 Euro/unit
Bulk-Price without tax, ex place:	99.000 Euro/unit

Pricing:	ex place ; for Germany additional 19% VAT.
Delivery:	ex location without transport, shipping available.
Delivery time:	instantaneously, visiting recommended;
Payment:	before loading,
Warranty:	no
Reservation of title:	until receiving the entire payment. Extended reservation of title is valid.

Michael Decker
Manager IRD Swiss



SPECIFICATION
OF
MWT-450
WIND TURBINE GENERATOR
FOR

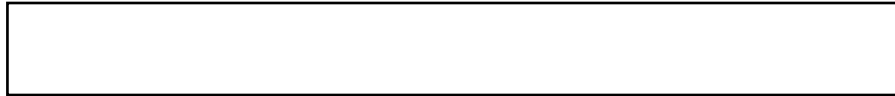

No. WM-96-041 Revision 3

April , 1997

MITSUBISHI HEAVY INDUSTRIES, LTD.
NAGASAKI SHIPYARD & MACHINERY WORKS

ca 

-CONTENTS-

	Page
1. INTRODUCTION 2
2. MWT-450 EQUIPMENT AND COMPONENT 3
2.1 Rotor	
2.2 Power Train	
2.3 Yaw System	
2.4 Tower	
2.5 Control System	
3. MWT-450 SPECIFICATION 12
3.1. Specifications	
3.2. Standards	
4. SCOPE OF SUPPLY 16
5. OUT OF SCOPE 18
6. AVAILABILITY GUARANTEE 19
7. WARRANTY 21
8. PERFORMANCE 22
Attachment 1. OUTLINE OF MWT-450 25
Attachment 2. POWER FACTOR 26
Attachment 3. ISO-9001 CERTIFICATE 27
Attachment 4. SECTIONAL DRAWING OF WTG 28
Attachment 5. SINGLE LINE DIAGRAM FOR WTG 31
Attachment 6. WIRING DIAGRAM FOR WTG 32
Attachment 7. INTERFACE OF MONITORING SYSTEM 33
Attachment 8. WTG INTERLOCK DIAGRAM 34

CDM
JH

1. INTRODUCTION

MWT-450 is the new generation of the high performance MHI wind turbine generators, designed for high annual energy capture at the minimum cost. This is achieved by the most efficient light-weight rotor blades optimized for the actual operating conditions, a 40 meter tower and the high efficiency and low maintenance power train.

The followings are the design features of the MHI wind turbine MWT-450.

- a) Upwind, three blade, variable pitch rotor for maximum energy capture and reliable operation.
- b) Active yaw system to track the wind direction.
- c) High efficiency, light weight planetary/helical gearbox.
- d) 500kW, 550V induction generator with a soft starter.
- e) High design wind speed.

The quality control of MWT-450's is in accordance with ISO-9001.

The outline of MWT-450 is shown in Attachment 1.

2. MWT-450 EQUIPMENT AND COMPONENT

The main components of a MWT-450 wind turbine are a rotor, a power train, a yaw system, a tower and an electrical system. Each of these components are described below.

2.1 Rotor

The rotor has three blades which can be rotated along its longitudinal axis by a pitch control mechanism for power regulation and aerodynamic braking. The blades are connected to the main shaft through a rigid hub (rotor head).

2.1.1 Blades

The rotor has three GFRP (Glass Fiber Reinforced Plastics) blades. Each blade is 18.3 meters long and employs the modified NASA LS(1)-04XX series airfoil. The construction is similar to the 12 meters blades, approximately 2,500 of which are now under successful operation with MWT-250 wind turbine, with improvements of aerodynamic and structural performance.

The airfoil is the modified LS(1)-04XX series airfoil as mentioned above, varying from a 13% thickness ratio at the tip to 30% thickness ratio near the root. The blade has 13.7 degrees twist from the root to the tip. The maximum chord length is 2,000 mm and tapers down to 700 mm at the tip. The blades are mounted to the rotor head at a cone angle of 0 degree.

2.1.2 Rotor Head

The rotor head connects the blades to the low speed shaft (main shaft).

The blade loads, static and dynamic wind loads and centrifugal forces, are transferred to the nacelle bedplate through the low-speed shaft bearings.

Pitch linkages for blade pitch control are installed in the rotor head.

2.1.3 Pitch control mechanism

The pitch control mechanism consists of a hydraulic power unit, servocontrol valves, linear actuators and linkages. The hydraulic power unit is mounted in the nacelle.

2.2 Power Train

The gearbox transmits the power from the rotor to the generator. A low speed (25 rpm) shaft connects the rotor head to the input shaft of a 1 : 60.0 gearbox. The gearbox employs planetary / helical gears, which increases the rotational speed to 1500 rpm. All gears are hardened and ground to provide long service life.

The output shaft of the gearbox is connected to the generator through a flexible coupling. A rotor brake is equipped on the high speed shaft and used primarily to secure the rotor from rotation during maintenance works.

The power train axis is inclined 5 degrees (tilt angle) from the horizontal.

The gearbox is mounted on a nacelle bedplate, which is designed to be a light weight main structural member.

The generator is a 550 V, 4 poles, 50 Hz, AC induction type, rated at 500 kW with a power factor of 0.95 (with capacitor) at rated output and the synchronous speed of 1500 rpm. The power factor is shown in Attachment 2.

2.3 Yaw System

In order to follow the shifts of wind direction, a four-point bearing with a bullgear is mounted between the nacelle and the tower. The nacelle to be rotated (yawed) by the electrically powered yaw drive.

A yaw brake system locks the nacelle to the tower whenever the turbine is not yawing, and provides yaw drag force when yawing.

2.4 Tower

The tower which supports the nacelle is a taper monopole, approximately 40m tall, which is supported by reinforced concrete foundation. The tower is designed to withstand the wind speed of 59.5 m/s (Instantaneous) at hub height.

2.5 Control System

The wind turbine generator control system is provided for the automatic, safe and reliable operation of the wind turbine generator at a remote, unattended site.

The control system automatically performs the following functions.

- (1) Power regulation over a wide range of wind speeds including start-up, shut-down, and generator grid connection.
- (2) Yaw control.
- (3) Protection against damages due to abnormal operating conditions and/or extreme environmental conditions.

2.5.1 Blade pitch control

The power output of the turbine is regulated by blade pitch control system, using the data from the anemometer and generator.

When the wind speed is below cut-in wind speed or above cut-out wind speed, the blades are feathered to prevent the rotor from excessive rotation.

At wind speeds between rated and cut-out, the blade pitch is controlled to maintain a constant power output (rated power).

2.5.2 Yaw control

Wind speed and yaw error, which is the angle between the nacelle direction and the wind direction, are sensed by the anemometer and wind vane sensor.

During the turbine operation, the yaw error is continuously monitored by the control system. The turbine is yawed, when the yaw error exceeds 15 degrees.

2.5.3 Safety system

The safety system, which enables automatic shut-downs, operates independently of all other wind turbine controls to protect the turbine from catastrophic failure.

Various sensors monitor key parameters, such as the rotor speed, generator current, electrical load, nacelle vibration, yaw error, pitch control system hydraulic pressure, controller failure, and so on.

If any sensor signal deviates from the normal operating range, the safety system automatically shuts down the wind turbine.

2.5.4 Handy Terminal

Yaw and pitch are able to be controlled manually by a handy terminal.

Following data are able to be read on the display of the handy terminal.

- 1) Trouble name
- 2) Cumulative power output in kWh
- 3) Power output in kW (average & instantaneous)
- 4) Wind speed (average & instantaneous)
- 5) Cumulative generator on-off cycles
- 6) Cumulative operation time
- 7) Yaw error (wind difference angle)
- 8) Cumulative yaw right turn cycles
- 9) Cumulative yaw left turn cycles
- 10) Current nacelle direction
- 11) Pitch angle (command & actual)
- 12) Current rotational speed

2.5.5 Power and Control Panel

Power and control panel is located at the base of the tower of each wind turbine. An operator is able to start up the turbine from this panel in accordance with adequate start up manual.

Universal controller with high performance CPU is mounted in the control panel of each wind turbine.

2.5.6 Computer Monitoring System

The computer monitoring system at remote, unattended site is provided as shown on attachment 7.

Also we can provide the RS485 interface of computer communicate cable if you want.

WIND TURBINE CONTROL SYSTEM

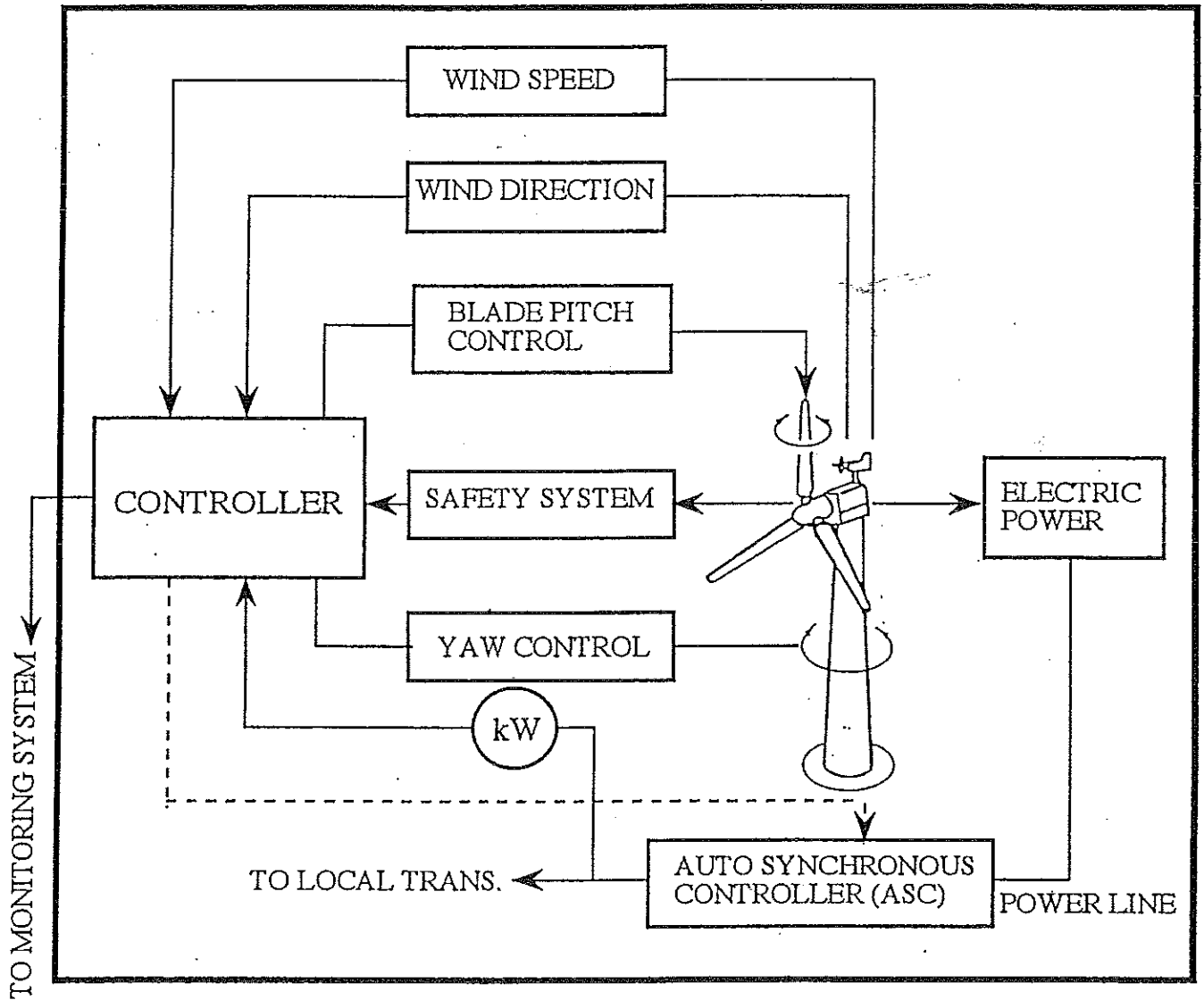

*Auto synchronous controller and controller are installed in pwer and control panel.

001 dh

PITCH CONTROL SYSTEM

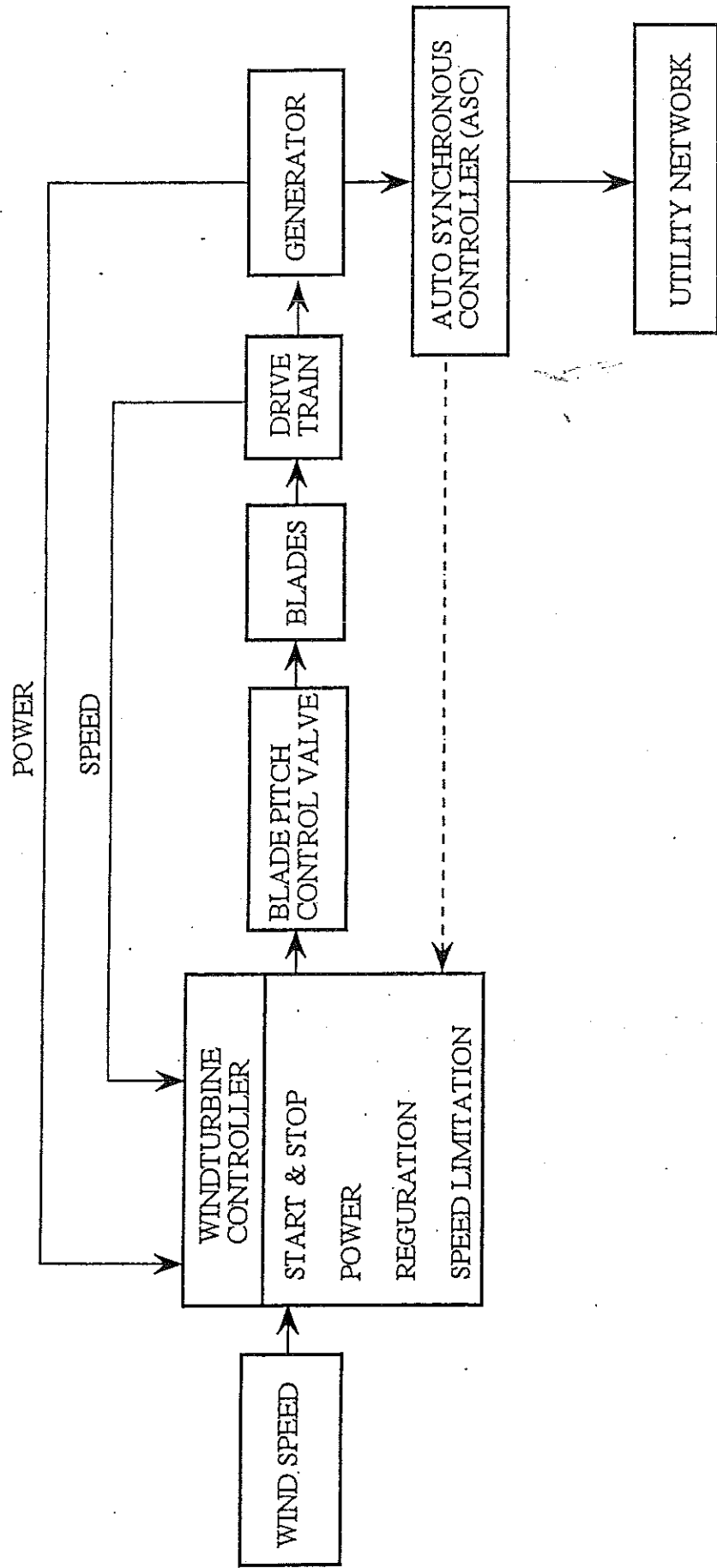

ca
yk

OVERSPEED PROTECTION SYSTEM

1st Step

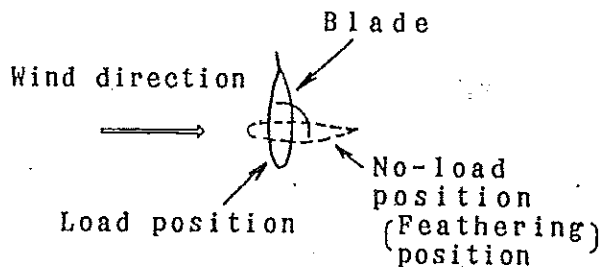
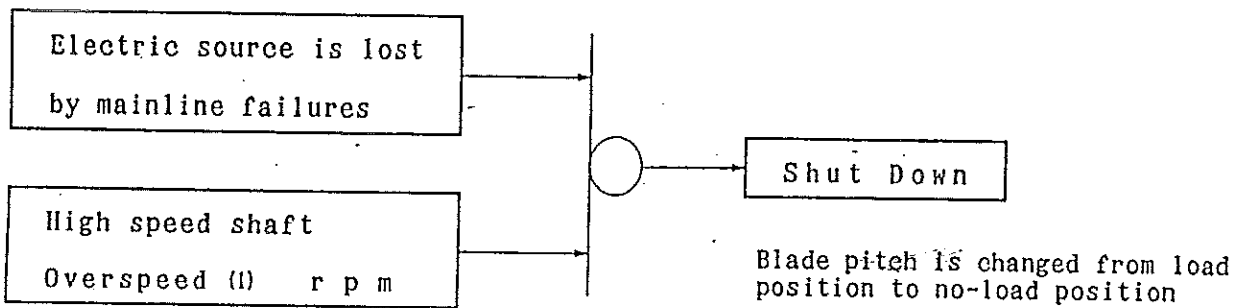

2nd Step

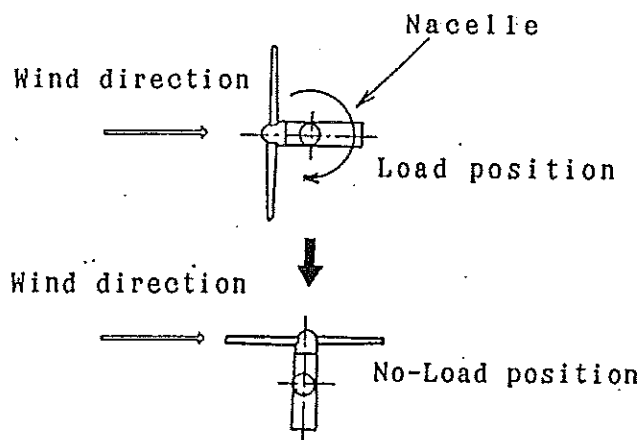
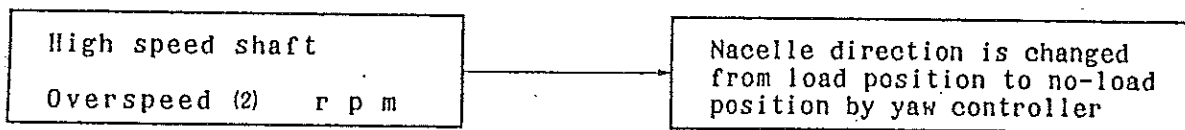

3rd Step

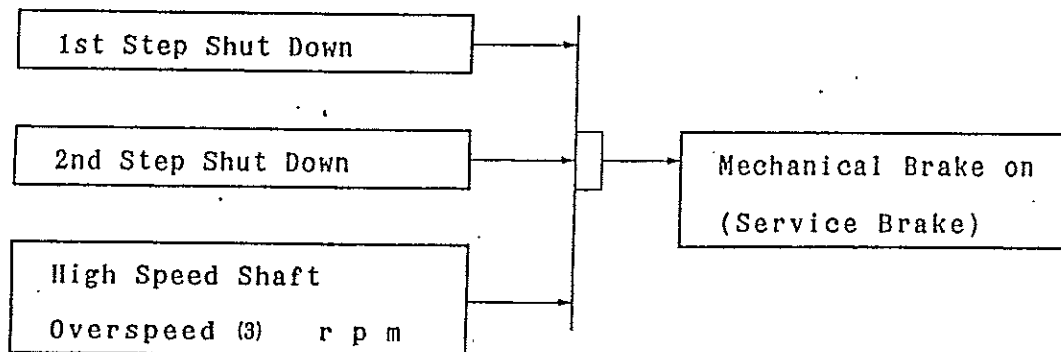

Handwritten initials and signature.

OVER POWER PROTECTION SYSTEM

1ST STEP

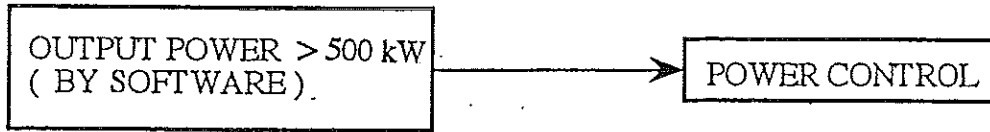

2ND STEP

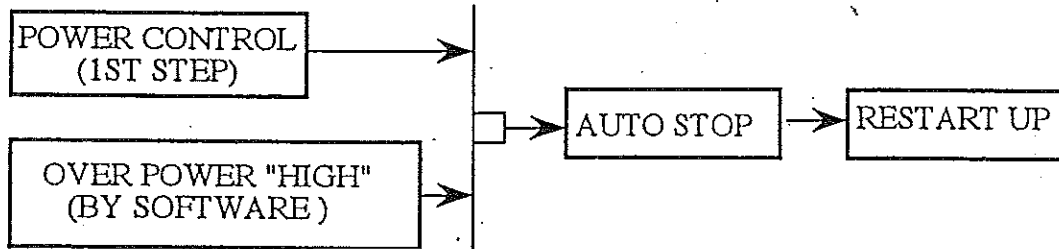

3RD STEP

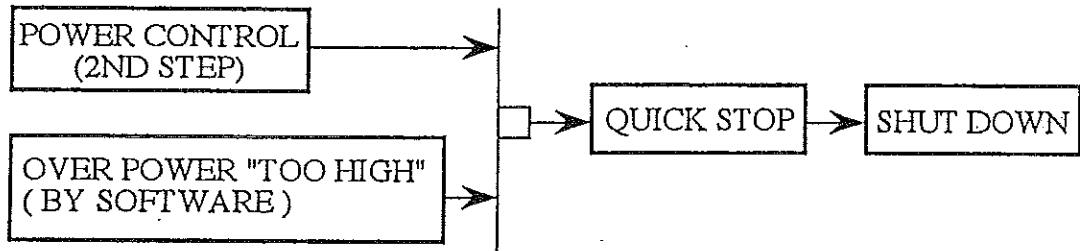

4TH STEP

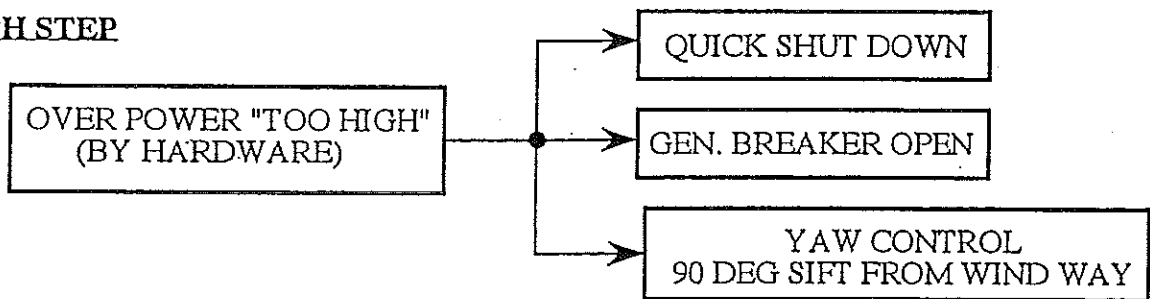

Handwritten signatures and initials.

3. MWT-450 SPECIFICATIONS

- SPECIFICATIONS AND STANDARDS

3.1 Specifications

3.1.1. Performance

Rated Output	500 kW
Wind Speed At Hub Height (Air Density 1.225 kg/m ³ , 10 minutes average)	
Cut-in	4.5 m/s
Rated	12.5 m/s
Cut-out	24.0 m/s, (28.8 m/s / Instantaneous)
Reset of Cut-out	20.0 m/s
Design Maximum	59.5 m/s (Instantaneous)

* Refer to Figure 1. for the power curve

3.1.2. Noise Level

Sound Power Level	less than 97dBA The measurement tolerance is expected to be more or less 1dBA than the above power level. (wind speed 6.6m/s at 10m high)
Tonal	less than 4dB Definited within IEC

3.1.3. Rotor

Number of Blades	3
Diameter	41 m
Rotational Speed	25 rpm
Rotational Direction	Clockwise (against wind direction)
Orientation	Upwind
Cone Angle	0 degrees
Tilt Angle	5 degrees

3.1.4 Blade

Length	18.3 m
Material	GFRP
Airfoil	NASA LS(1)-04XX
Twist	13.7 degrees
Chord Length	
Tip	700 mm
Root	2,000 mm

3.1.5 Gearbox

Type	Planetary & Helical
Gear Ratio	1 : 60
Rating (Output)	500 kW
Rotational Speed	
High Speed Shaft	1,500 rpm
Low Speed Shaft	25 rpm

3.1.6 Generator

Type	Induction Generator
Rated Capacity	500 kW
Power Factor	0.95 with capacitor, at rated output * Refer to Attachment 2. for power factor.
Number of Poles	4
Synchronous Speed	1,500 rpm
Voltage	550 V
Frequency	50 Hz
Enclosure & Protection	Totally-Enclosed Fan Cooled Type
Rotor Type	Squirrel-Cage Rotor With Anti-Friction Bearing
Insulation	F
Rating	Continuance

3.1.7 Yaw Control

Type	Active
Yaw Drive	Induction Motor
Rated Power	1.5 kW
Speed	
High Speed Shaft	1,450 rpm
Low Speed Shaft	1.10 rpm

3.1.8 Control System

Power Regulation	Full span pitch control
Yaw Orientation	Active control

3.1.9 Safety System

Automatic Shutdown	Over speed
	Abnormal Vibration
	Generator Overcurrent
	Generator Ground Overcurrent and others.

3.1.10 Tower

Type	Taper Monopole
Hub Height	40 m
Ground Clearance	20 m
Top Diameter	2.0 m
Base Diameter	3.2 m

3.1.11 Environment Condition

Temperature	-20 ~ +40 degrees
Elevation	1,000 meters or lower above sea level.

3.1.12 Weight (Approximate)

Above Tower	32 ton
Tower	28 ton
Total	60 ton

3.2 Standards

3.2.1 Technical Standards

MWT-450 wind turbine generator and its electrical equipments will be manufactured in accordance with Japanese standards as follows.

- JIS (Japanese Industrial Standard)
- JEM(The Standard of Japan Electrical Manufacturer Association)
- JEC (Japanese Electrotechnical Committee)
- Exclude CE Marking

3.2.2 Quality Control

The quality control of MWT-450's is in accordance with ISO-9001.

8. PERFORMANCE

8.1 Standard Power Curve

The standard power curve is shown in the Figure 1 and Table 1,

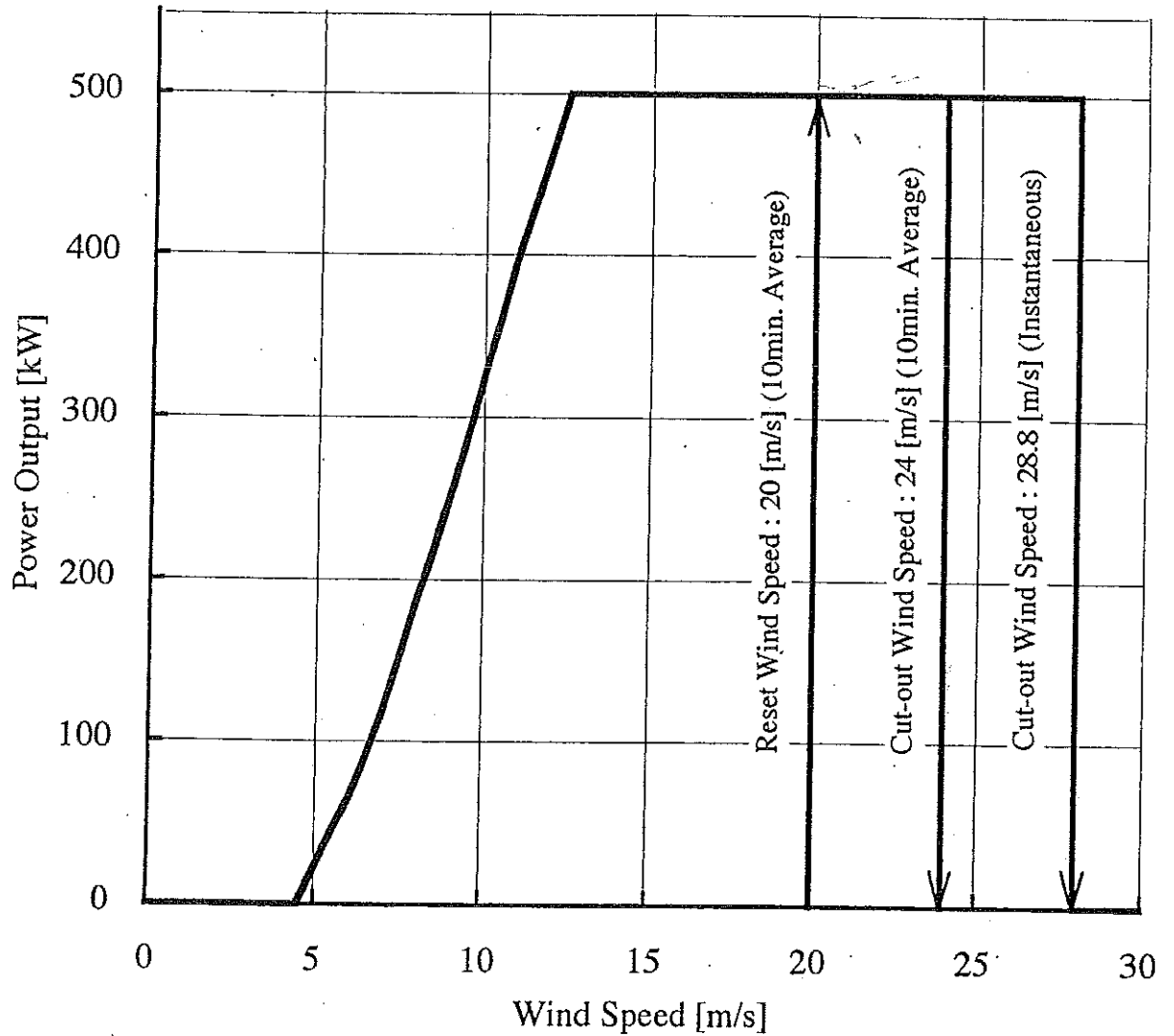

Figure 1. Standard Power Curve of MWT-450
(Air Density : 1.225 kg/m^3)

These data are valid for the wind data measured at the hub height
Losses are not included in this power curve. Refer to Section 8.

001 JH

Table 1. Standard Power Curve of MWT-450

(Air Density : 1.225 kg/m³)

Wind Speed [m/s]	Power Output [kW]
4.5	0
5.0	22
5.5	43
6.0	64
6.5	90
7.0	115
7.5	151
8.0	187
8.5	216
9.0	247
9.5	287
10.0	325
10.5	361
11.0	401
11.5	433
12.0	466
12.5	500
13.0	500
13.5	500
14.0	500
15.0	500
16.0	500
17.0	500
18.0	500
19.0	500
20.0	500
21.0	500
22.0	500
23.0	500
24.0	500
25.0	0
26.0	0
27.0	0
28.0	0
29.0	0
30.0	0

These data are valid for the wind data measured at the hub height.

Losses are not included in this power curve. Refer to Section 8.2.

8.2 Expected Power Output

The expected power output at sub-station, P , can be calculated from the aerodynamic power output, P_0 , using the following equation. P_0 can be read on the aerodynamic performance curve.

$$P = P_0 \times (1 - e_C) \times (1 - e_T) \times (1 - e_E) \times (1 - e_A) \times C_A$$

Where,

- P : Power output at substation (Actual output)
- P_0 : Aerodynamic power output (Calculated output)
- e_C : Control loss factor (2%)
- e_T : Turbulence loss factor (3%)
- e_E : Electric transfer loss factor
- e_A : Array loss factor
- C_A : Correction coefficient of anemometer

Attachment 1. Outline of MWT-450

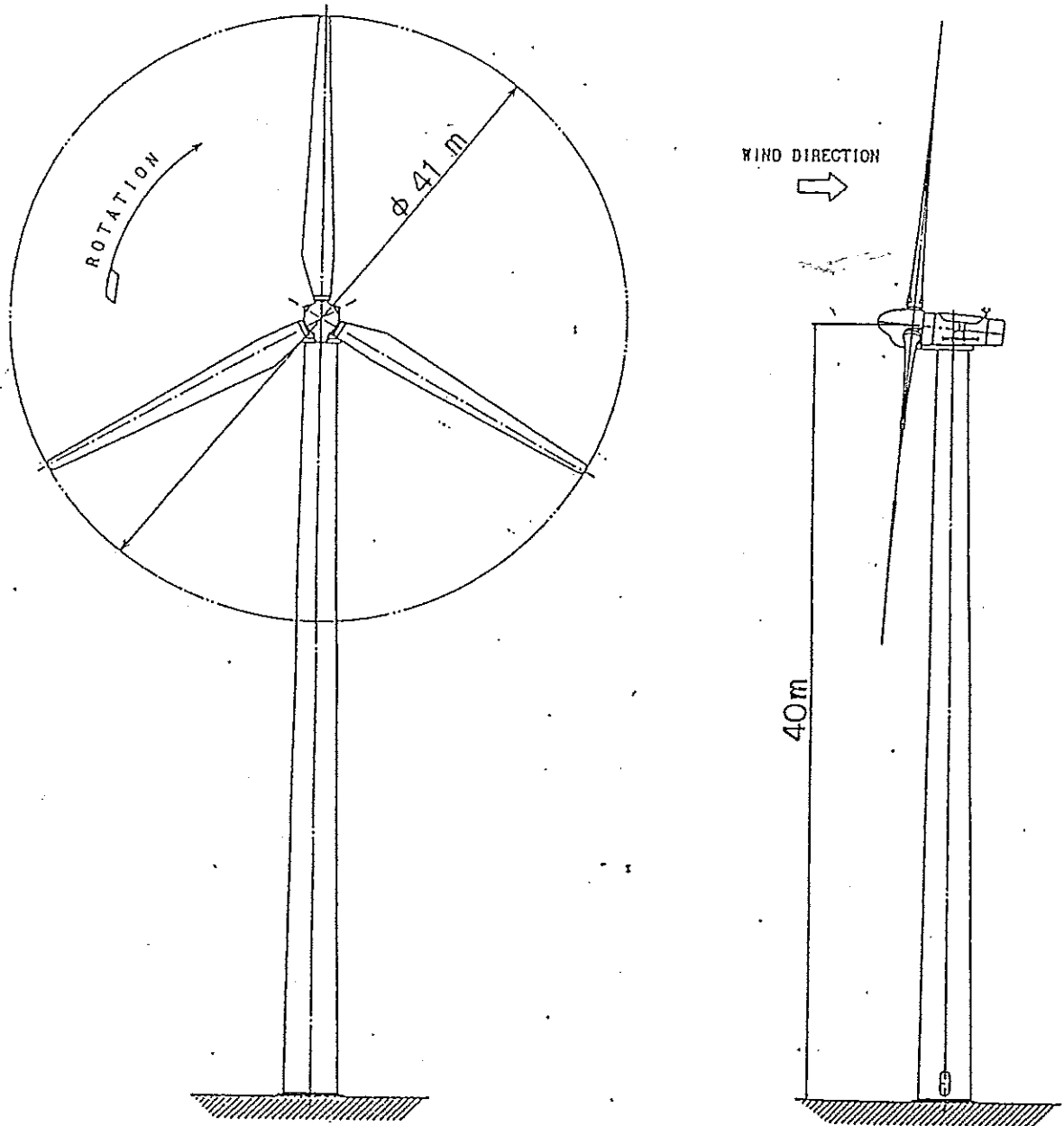

Handwritten marks and signatures.

Attachment 2. Power Factor

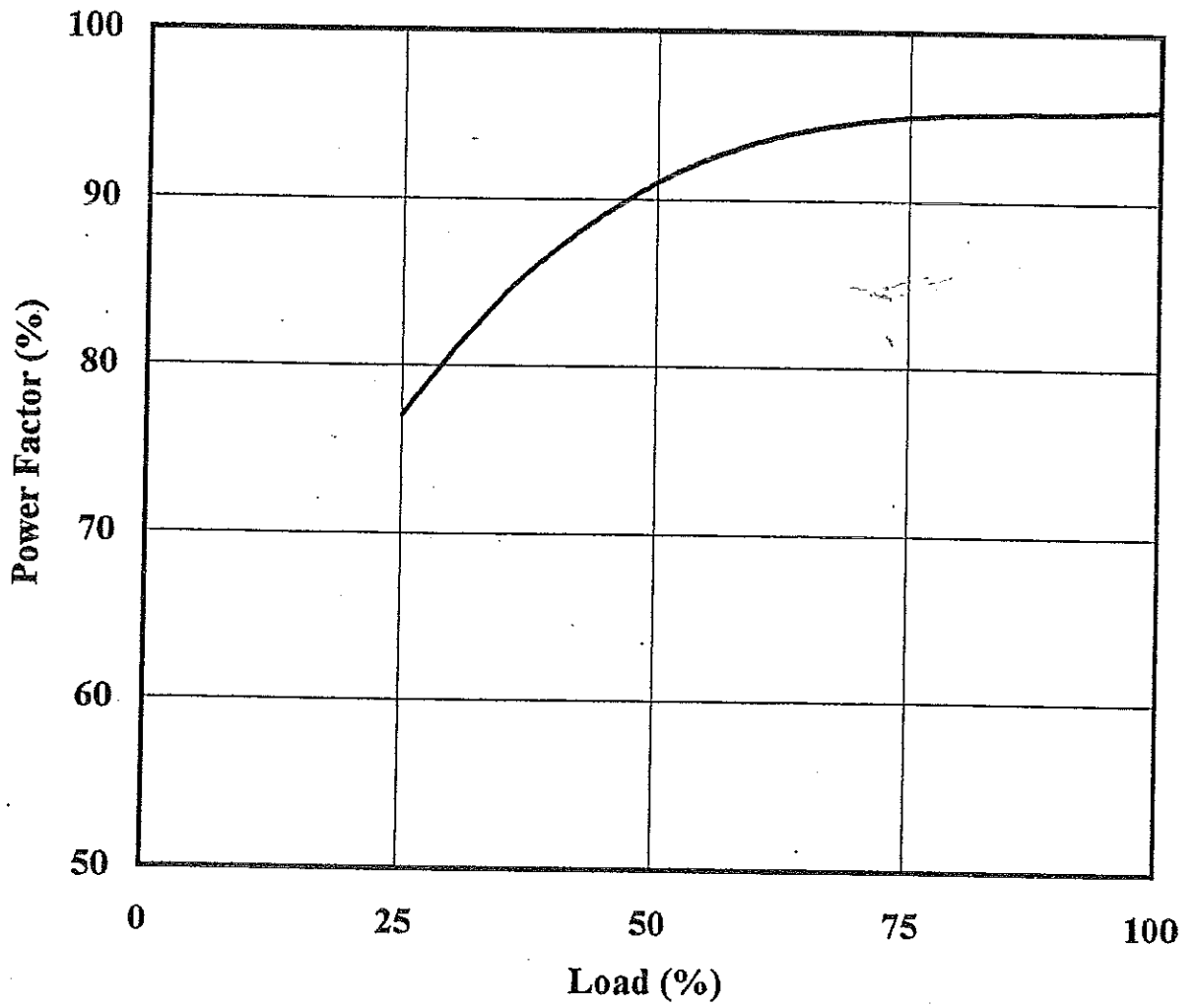

Load (%)	Power Factor (%)
25	77.0
50	91.0
75	95.0
100	95.5

ca
of



DET NORSKE VERITAS
QUALITY SYSTEM CERTIFICATE

Certificate No. 2982

This is to certify that

THE QUALITY SYSTEM
of

**MITSUBISHI HEAVY INDUSTRIES, LTD.
NAGASAKI SHIPYARD & MACHINERY WORKS**

**NAGASAKI SHIPYARD:
1-1, AKUNOURA-MACHI,
NAGASAKI-CITY 850-91,
JAPAN.**

**SAIWAI-MACHI PROD. SHOP:
6-12 SAIWAI-MACHI,
NAGASAKI,
JAPAN.**

Has been found to conform to the Quality System Standard

ISO 9001:1994, JIS Z9901:1994

This Certificate is valid for the following product or service ranges

DESIGN AND MANUFACTURE OF WIND TURBINE GENERATOR

Place and date

London 24th January 1997

for the Accredited Unit

Det Norske Veritas QA Ltd.

Management Representative

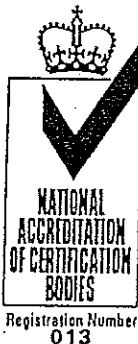

This certificate is valid until

22nd October 1999

Original certificate valid from: 22nd October 1993

Lead Auditor

10510

Lack of fulfilment of condition as set out in the Appendix may render this certificate invalid

The use of the Accreditation Mark indicates accreditation in respect of the activities covered by the accreditation number 013

10
A1
PLANT RECORD
IS
PUBLIC WORKS
PROJECT

1 2 3 4 5 6 7 8 9

Attachment 4. SECTIONAL DRAWING OF WTG

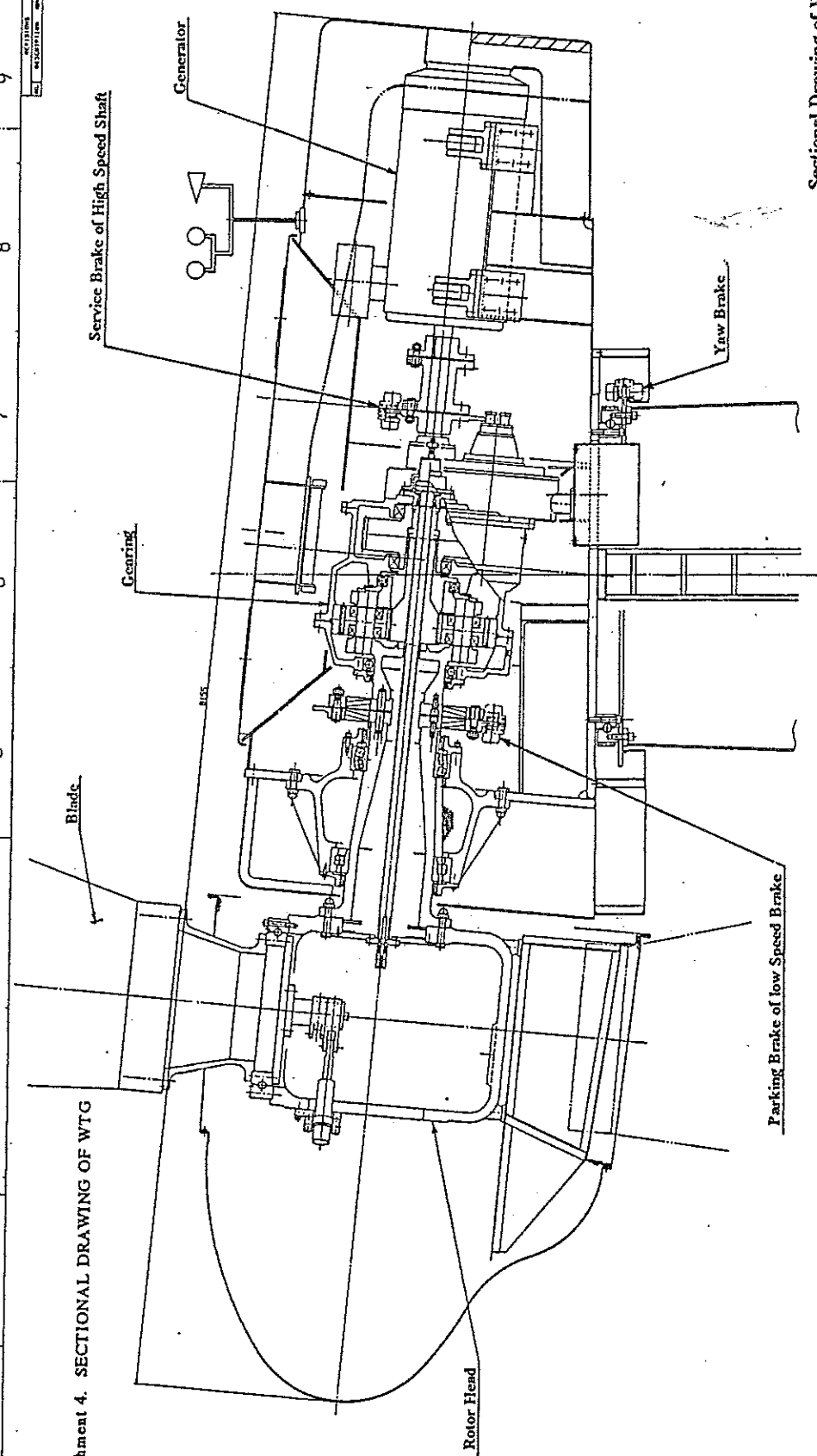

Sectional Drawing of WTG (1/3)

PRERIMINARY

NO.	REV.	DATE	BY	CHKD.	DESCRIPTION
1					
2					
3					
4					
5					
6					
7					
8					
9					
10					

Handwritten signature or initials.

REVISIONS		PLAN RECORD	
NO.	DESCRIPTION (DATE)	DATE	PROJECT

TAG. No	FRAME (A)	AMPERE RATING (A) AT AMBIENT TEMPERATURE 40°C	INTERRUPTING CAPACITY (sym kA)
MCCB 1	800	700	25 (at 800V)
MCCB 2	100	40	5 (at 690V)
MCCB 3	50	15	2.5 (at 690V)
MCCB 4	50	10	2.5 (at 690V)
MCCB 5	50	30	2.5 (at 590V)
MCCB 6	30	15	—
CP 1	30	3	—
CP 2	30	7	—
CP 3	30	3	—

ISO METRIC SCREW THREADS
PREVIOUS DRAWING NO.

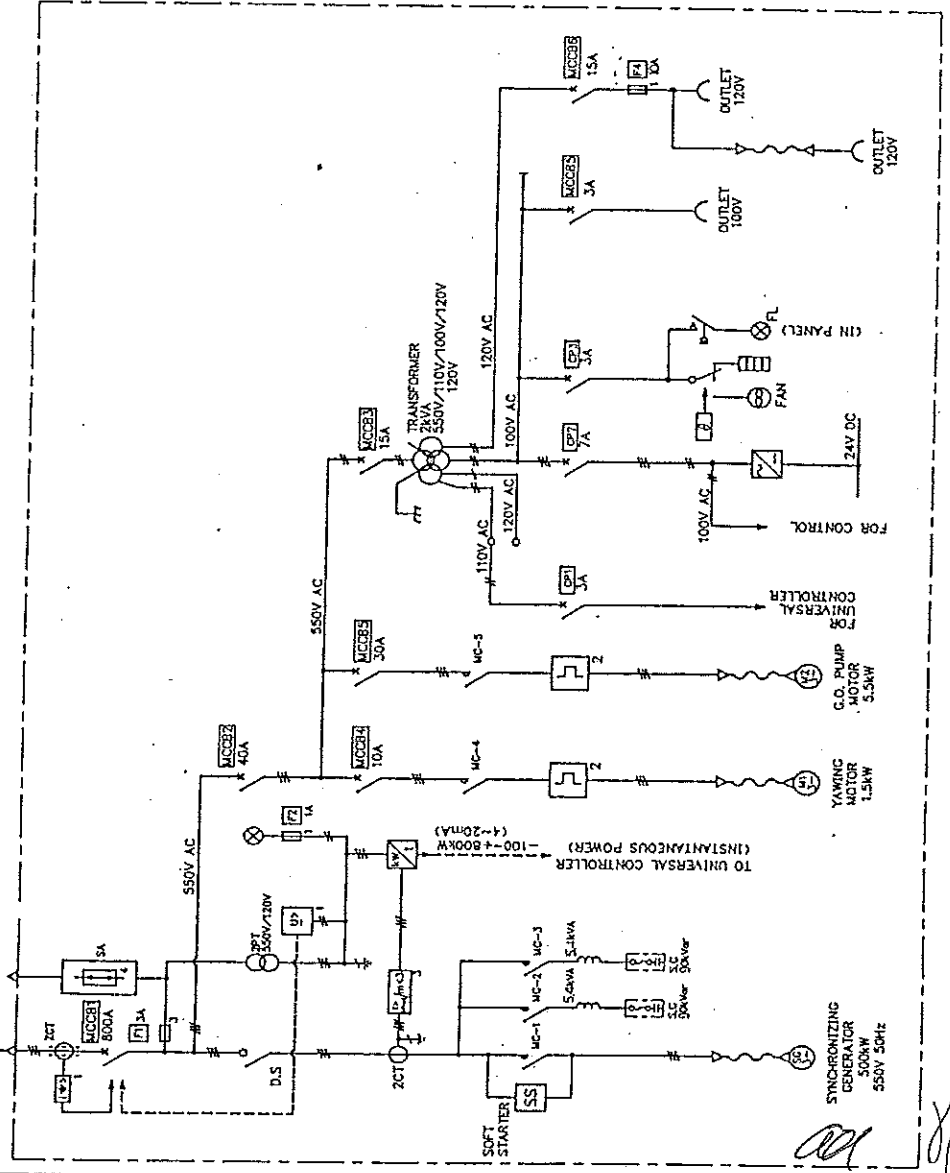

- NOTE**
- : MHT SCOPE
 - ⊗ : PILOT LAMP
 - ⊙ : CURRENT TRANSFORMER
 - ⊕ : FLUORESCENT LAMP
 - ⊖ : ZERO PHASE CURRENT TRANSFORMER
 - ⊞ : HEATER
 - ⊟ : FUSE
 - ⊠ : THERMOSTAT
 - ⊡ : CABLE HEAD
 - ⊢ : SWITCHING POWER SUPPLY
 - ⊣ : FLEXIBLE CABLE
 - ⊤ : POWER CONVERTER
 - ⊥ : MAGNETIC CONTACTOR
 - ⊦ : REACTOR
 - ⊧ : REACTOR
 - ⊨ : THERMAL OVERLOAD RELAY
 - ⊩ : EARTH LEAKAGE RELAY
 - ⊪ : STATIC CAPACITOR
 - ⊫ : OVER CURRENT (TIME DELAY), OPEN PHASE PROTECTION RELAY
 - ⊬ : CIRCUIT PROJECTER
 - ⊭ : SURGE ABSORBER
 - ⊮ : POTENTIAL TRANSFORMER
 - ⊯ : DOOR SWITCH

Vila do Bispo Project

SINGLE LINE DIAGRAM FOR WTC

ELECTRONICS & COMPUTER PRODUCTS SECTION

APPROVED: [Signature] DATE: [Date]

DESIGNED: [Signature] DRAWN: [Signature]

SCALE: 1/100

PROJECT NO. 04073

ITEM NO. 66800

DRAWING NO. 66800-7011

REVISED 0

MITSUBISHI HEAVY INDUSTRIES, LTD.

NAGASAKI SHIPYARD & MACHINERY WORKS

Attachment 6. WIRING DIAGRAM FOR WTG

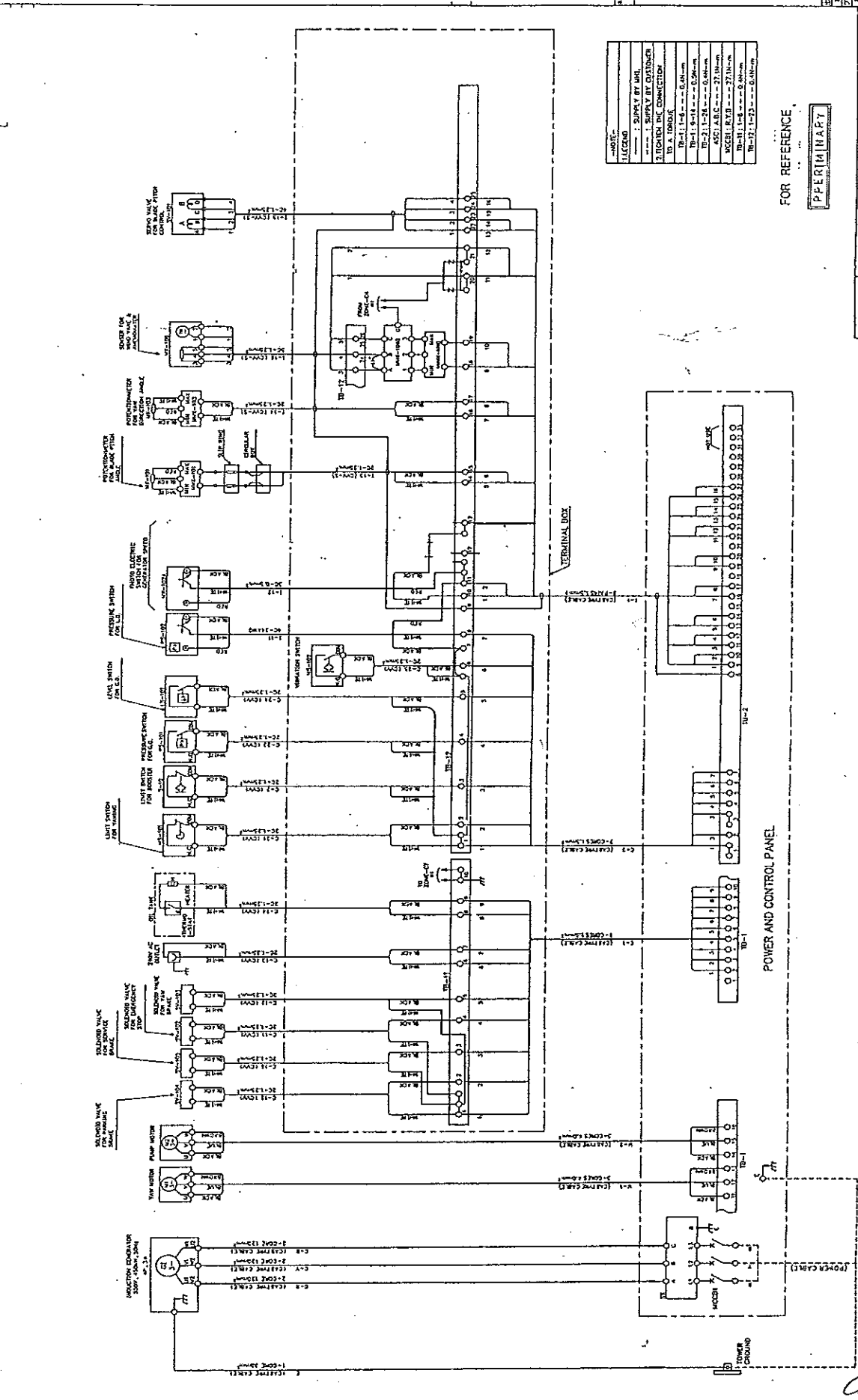

REVISIONS	NO.	DESCRIPTION	DATE	BY	CHKD.

FOR REFERENCE

PERMANENT

WIRING DIAGRAM FOR WTG

66800 (EX-2) 66800-5021 0

A. MITSUBISHI HEAVY INDUSTRIES, LTD.
NAGASAKI SHIPYARD & MACHINERY WORKS

Attachment 7. INTERFACE OF MONITORING SYSTEM

REVISIONS		NO.	DESCRIPTION (DATE)	ZONE	BY	CHKD

PLAN RECORD A2

ISOMETRIC SCREW THREADS
PREVIOUS DRAWING NO.

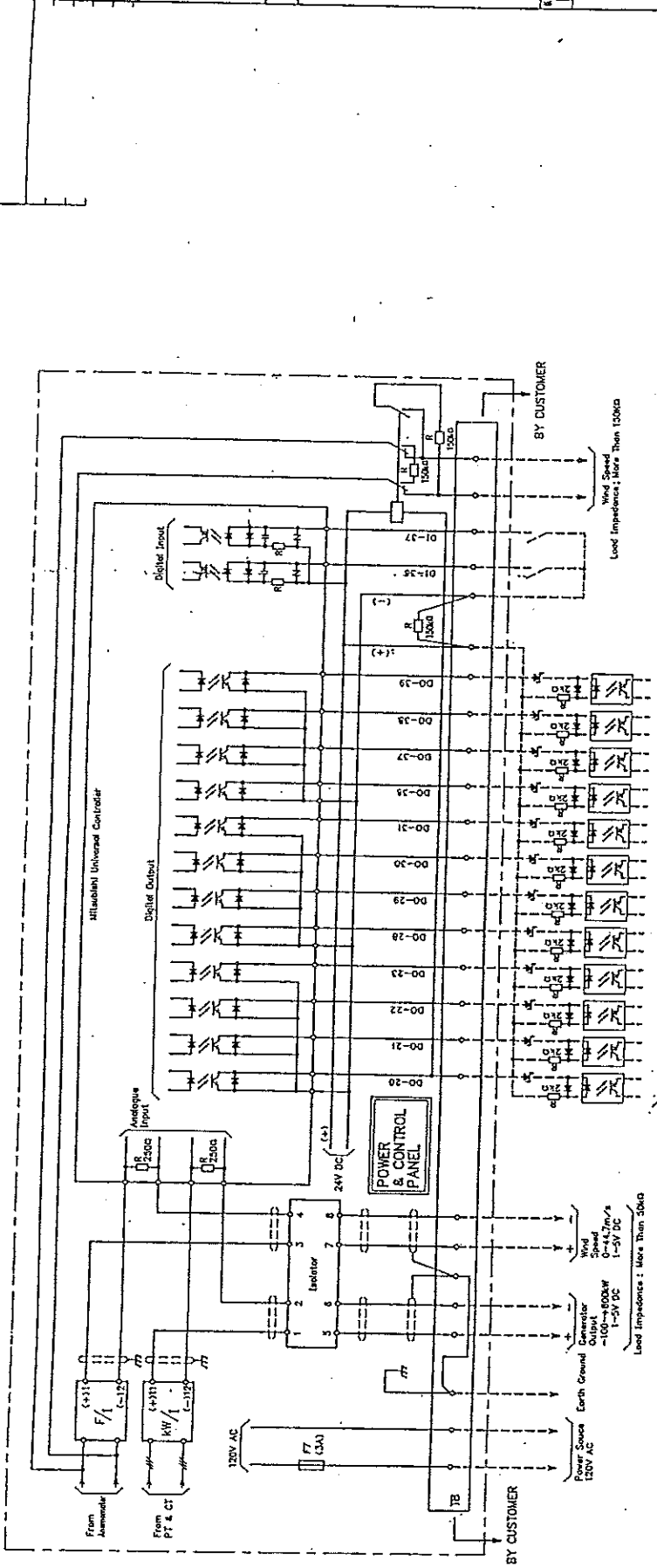

- Utility Ready
- Turbine Ready
- On Line
- WTG Abnormal
- Reselectable Abnormal
- Remote Stop Feed Back
- 0% Level Low
- Over Current or Signal-Phase
- Remote-Stop Command...
- Remote Start Command

FOR REFERENCE
PRERIMINARY

HYD. INST. PRESS. SUPP.	W/term	APPROVED	CONTROL & ELECTRICAL SYSTEM ENGINEERING SECTION
AT SITE	04000	<i>[Signature]</i>	
CONFIRMED	W/term	BY	
SCALE	1:1	DATE	
ORDER	66800	PROJECT NO.	66800-7023
ITEM	2	DRAWING NO.	66800-7023
REV.	0		

MITSUBISHI HEAVY INDUSTRIES, LTD.
NAGASAKI SHIPYARD & MACHINERY WORKS

86-CM-SYS01
DRAWN MAR. 8. '95

